

INSTRUÇÕES DE MONTAGEM

INSTRUCCIONES DE MONTAJE
ASSEMBLY INSTRUCTIONS



Vídeo de Montagem
Vídeo de montaje
Assembly Video

PENTEADEIRA CLOE | PENSION CLOE | CLOE PENTHOUSE D911-05 BRANCO HP

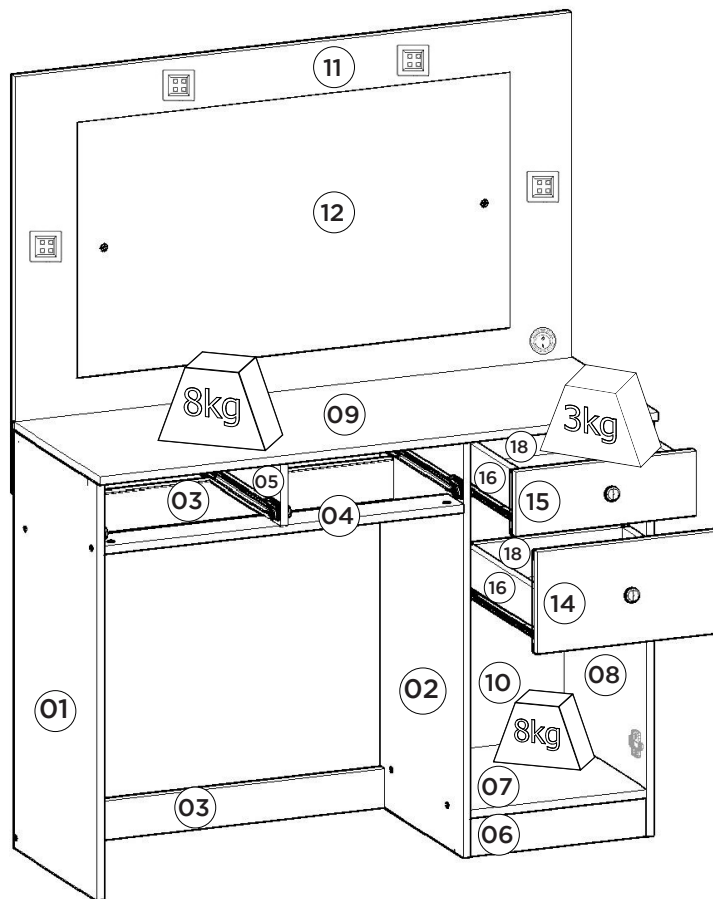
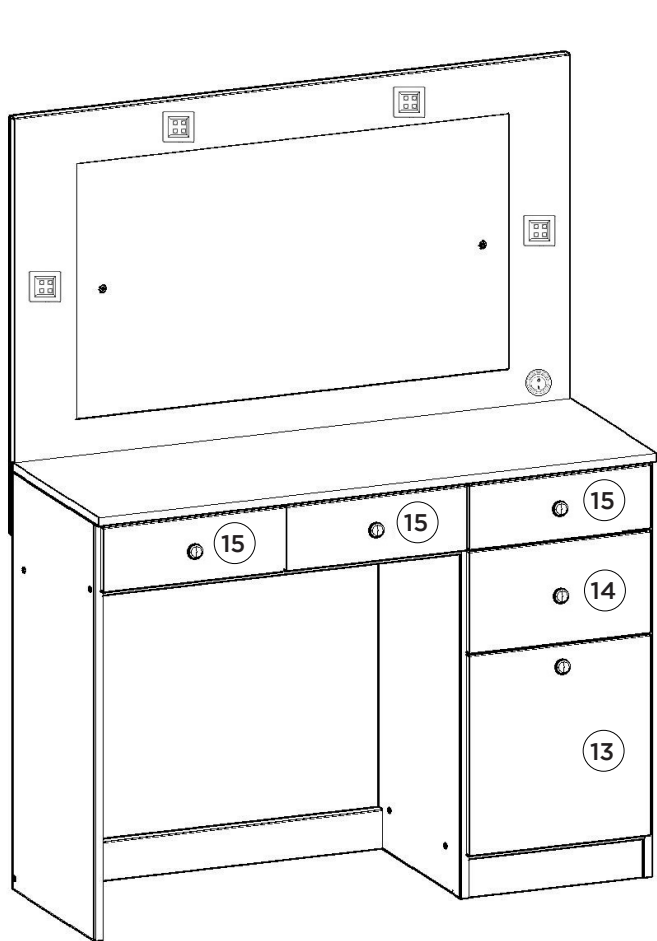

Pesos máximos recomendados com carga distribuída
Peso máximo recomendado con la carga distribuída
Recommended maximum weights with evenly distributed.

Requisitos para montagem Requisitor para la montaje Assembly Requirements

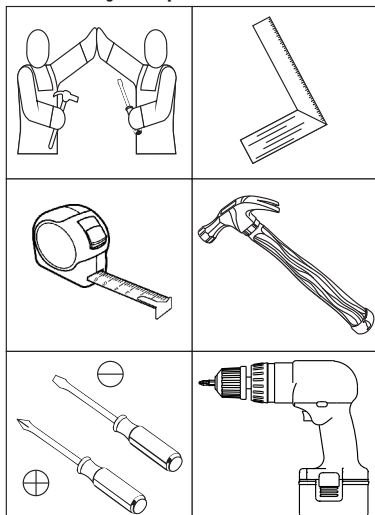

Imagens meramente ilustrativas
Imágenes meramente ilustrativas
Images for illustration only

AVISO

Para limpeza de seu móvel, use uma flanela seca ou umedecida, e não utilize produtos químicos que possam danificar seu produto.

SISTEMA DE MONTAGEM

O sistema de montagem dos produtos, funciona de acordo com a ordem crescente dos números indicados no desenho. Ex: 01, 02, 03, 04... até a conclusão da montagem.

ADVERTENCIA

Para limpieza de su móvil, use una flanela seca o húmeda, y no utilice productos químicos que puedan dañar su producto.

SISTEMA DE MONTAJE

El sistema de montaje de los productos funciona de acuerdo con el orden creciente de los números indicados en el dibujo. Ej.: 01, 02, 03, 04... hasta la conclusión del montaje.

NOTICE

To clean your furniture, use a dry or wet cloth, and do not use chemicals that may damage your product.

ASSEMBLY SYSTEM

The products' assembly system works according to the increasing order of the indicated numbers. For example: 01, 02, 03, 04 ... to the end of the assembly.

1º

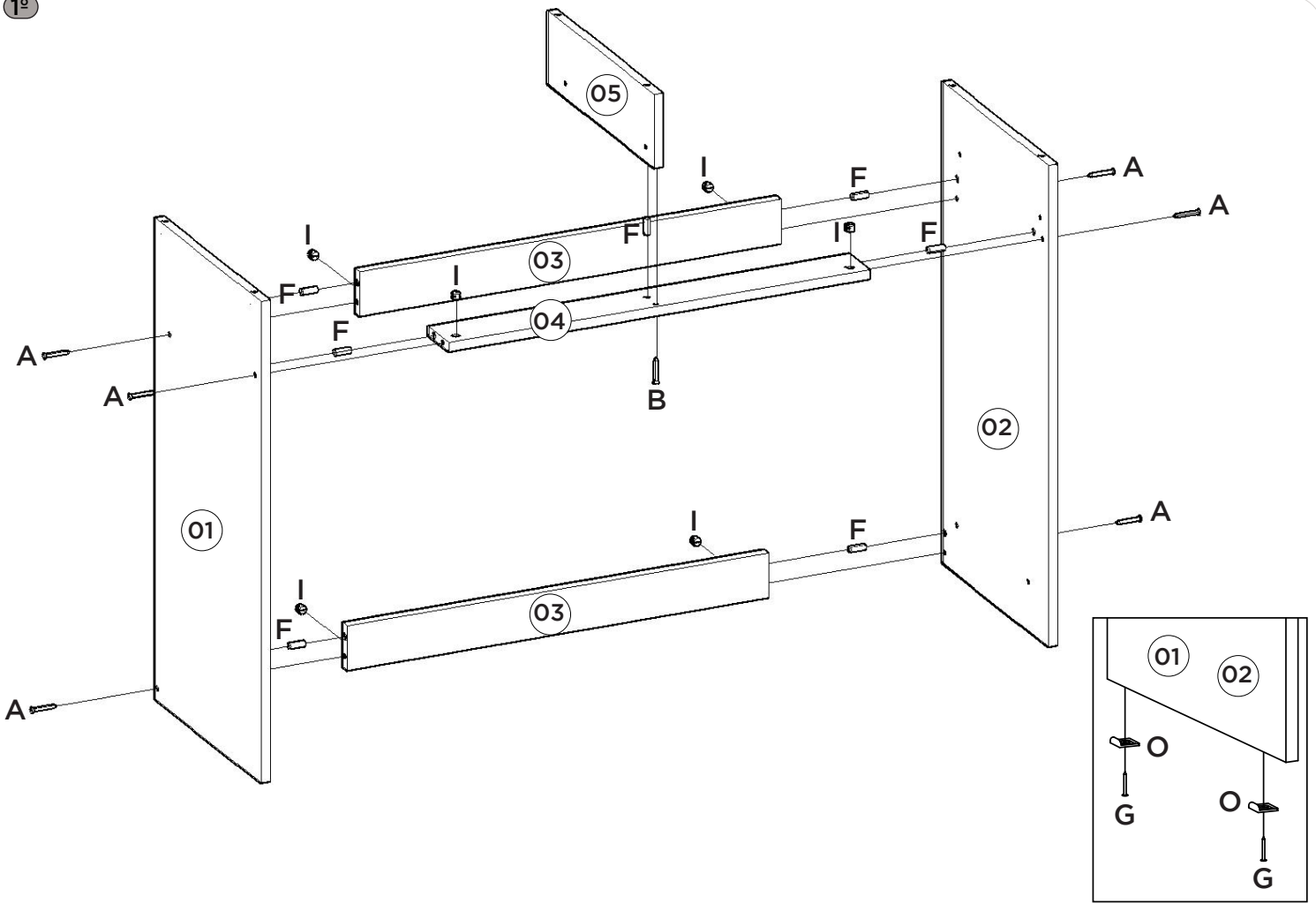

2º

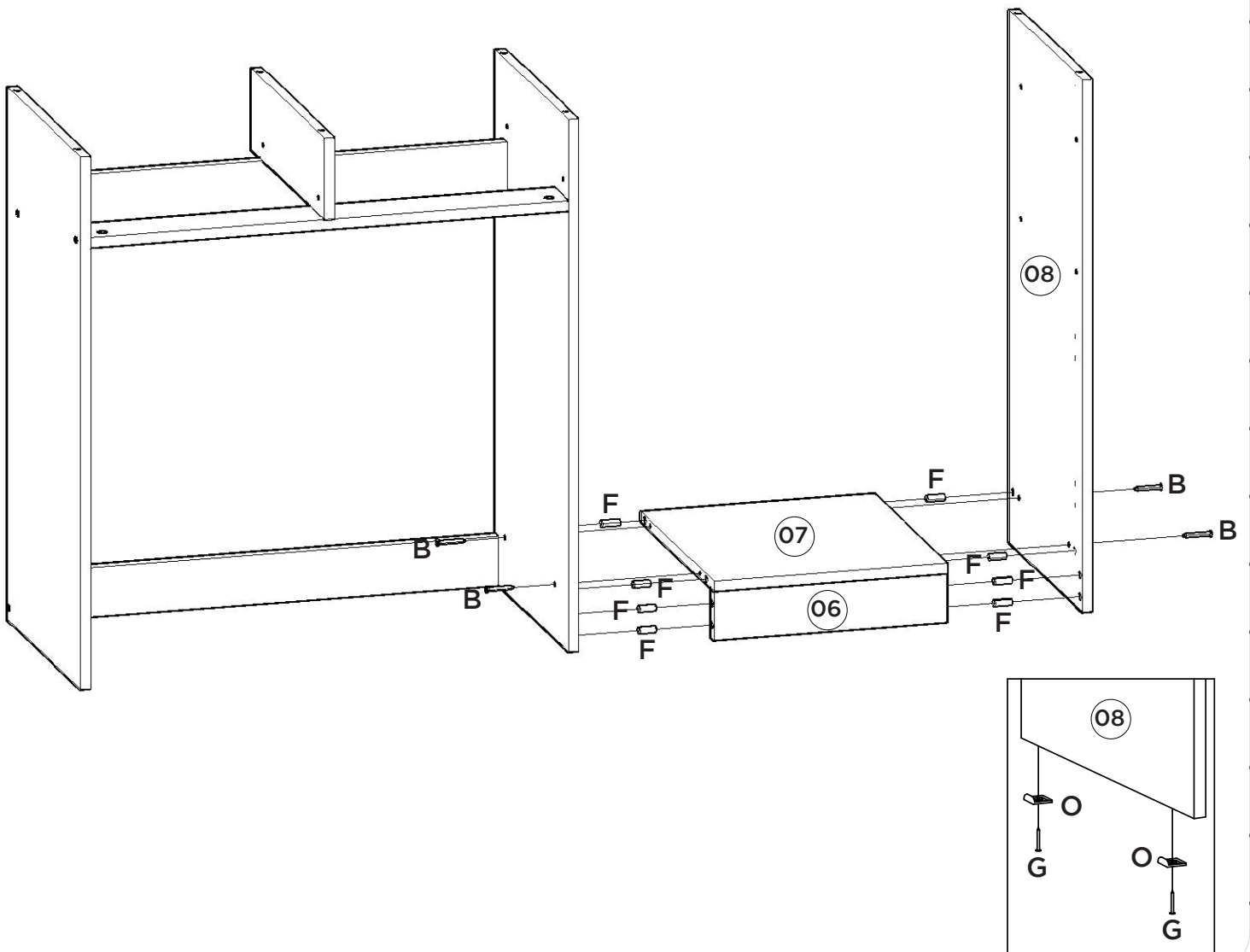

3°

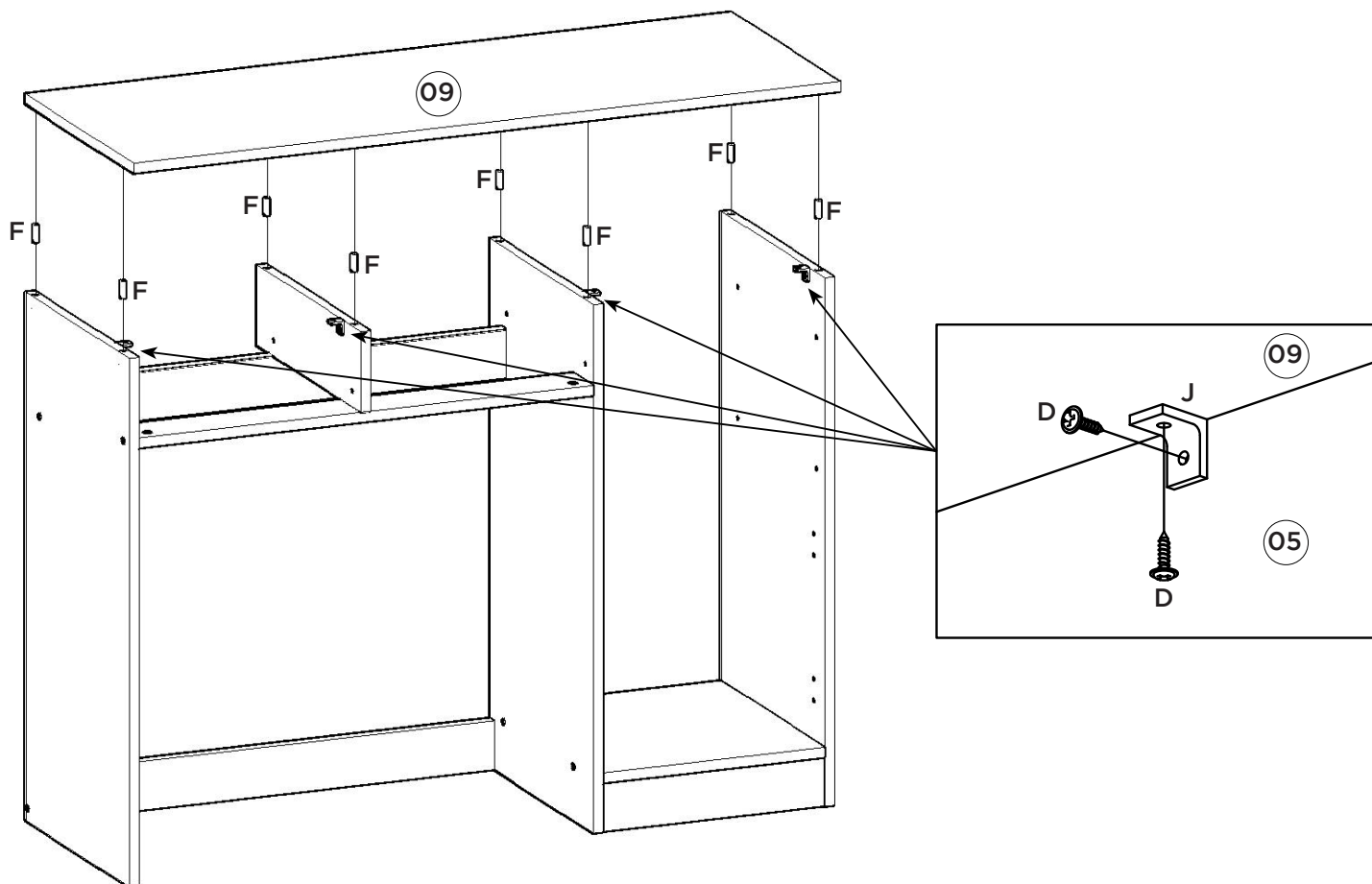

4°

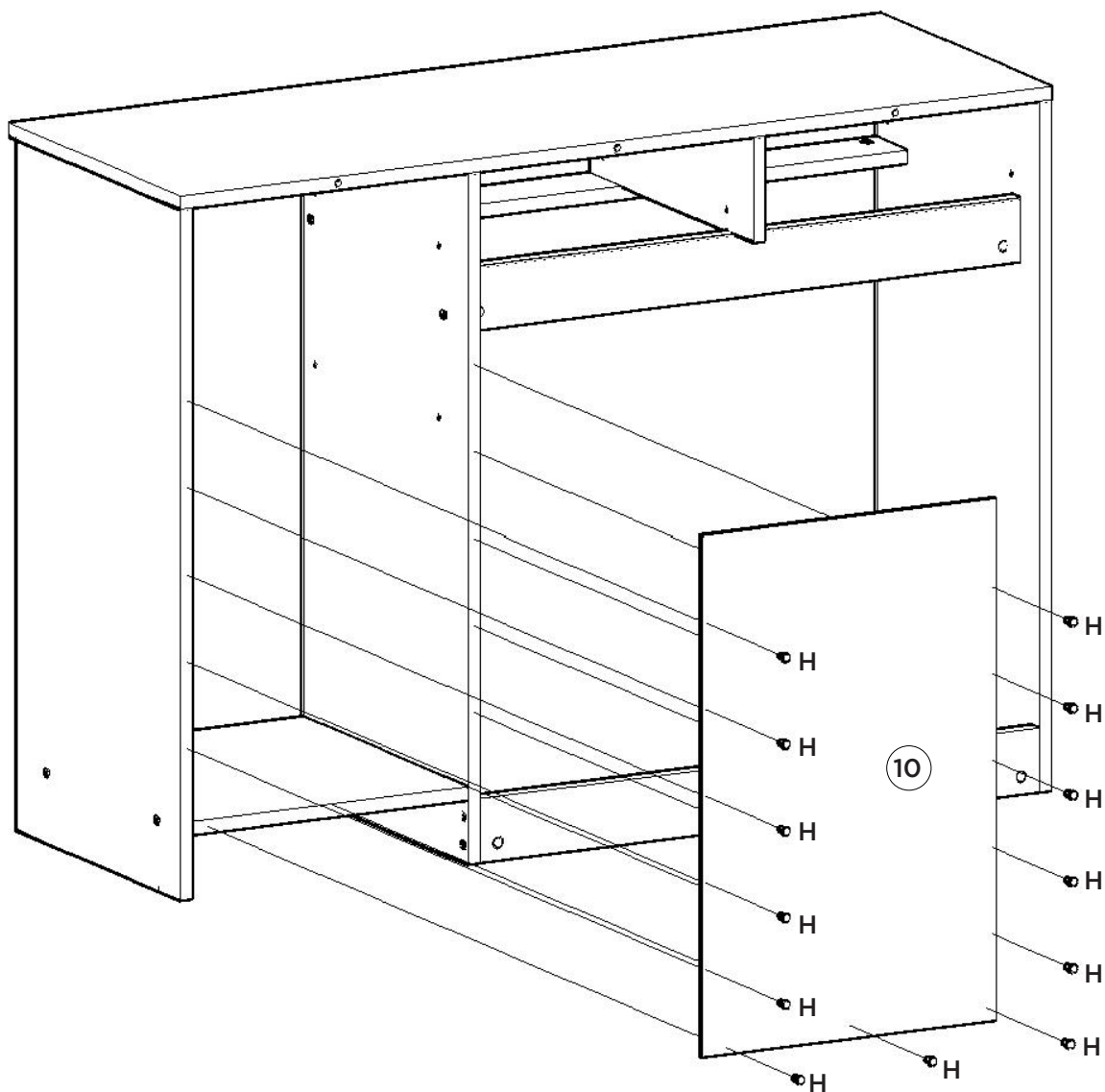

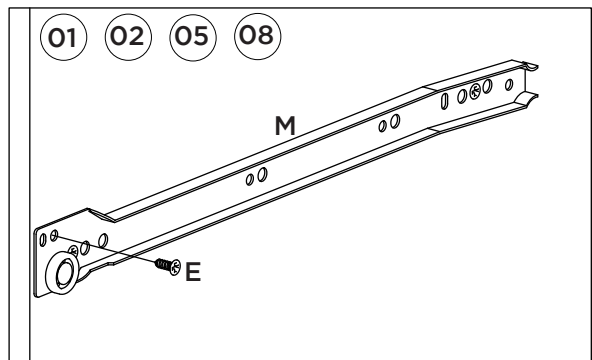
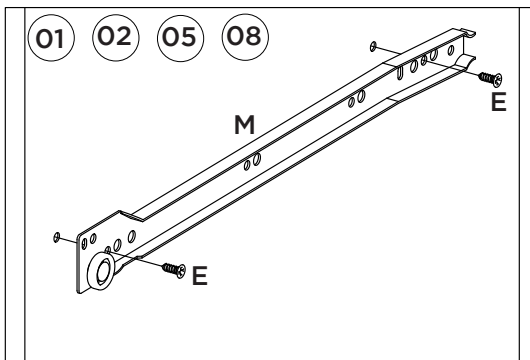
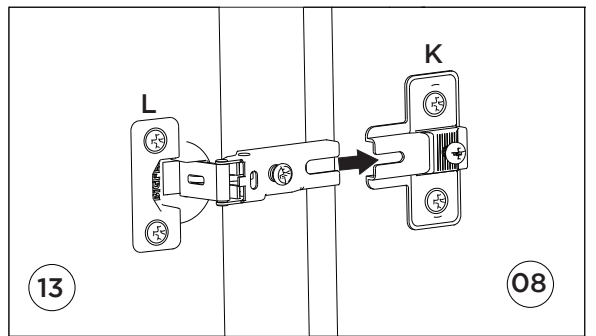
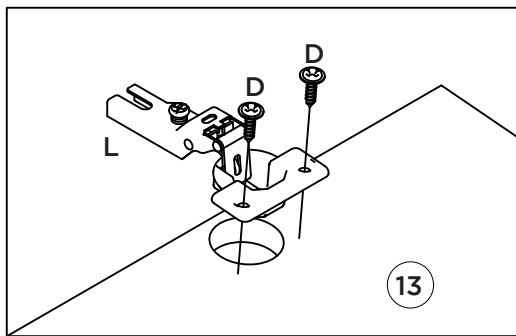
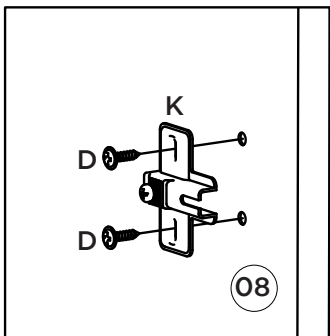
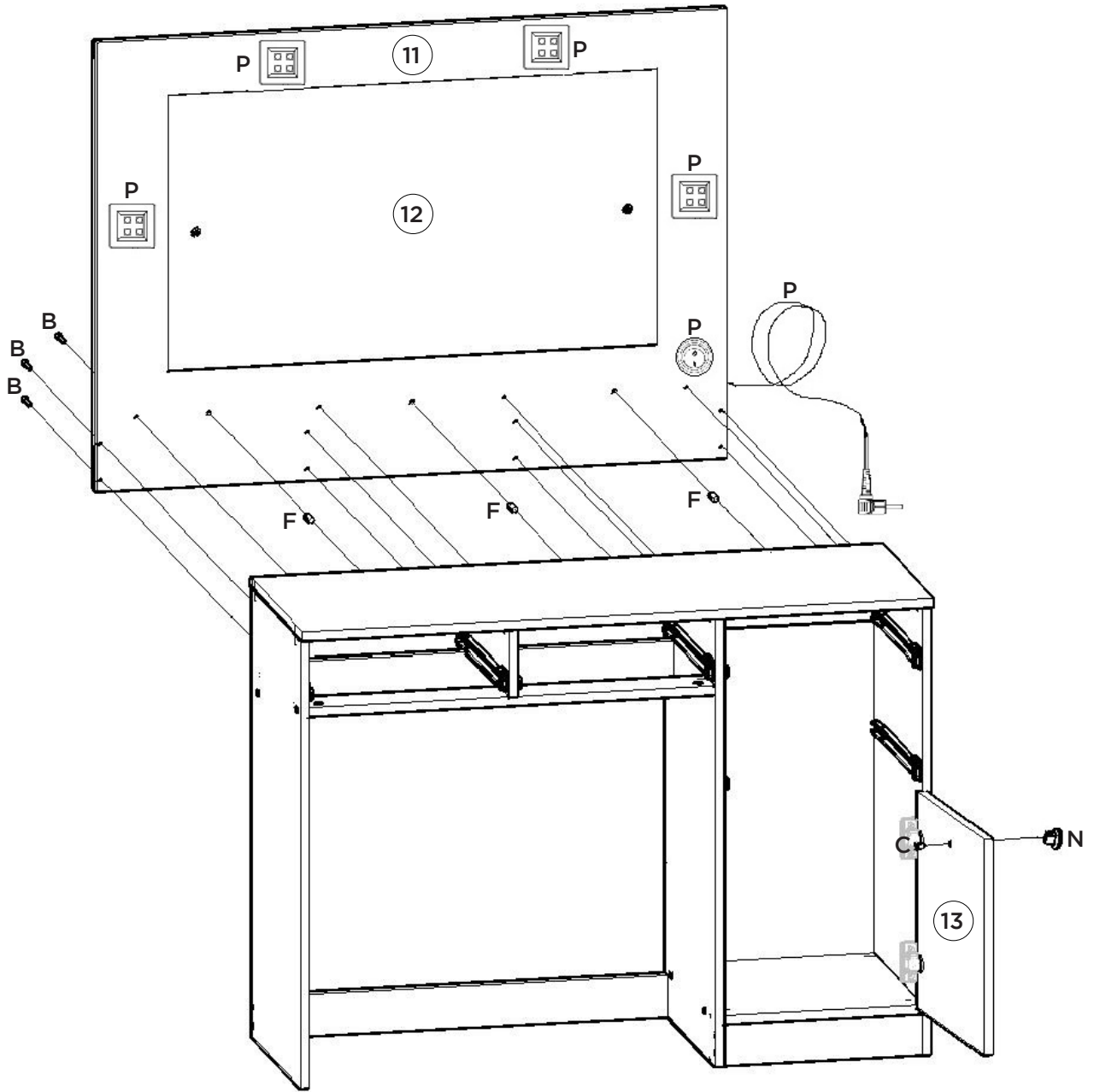

Vista Traseira

Vista Trasera

Back view

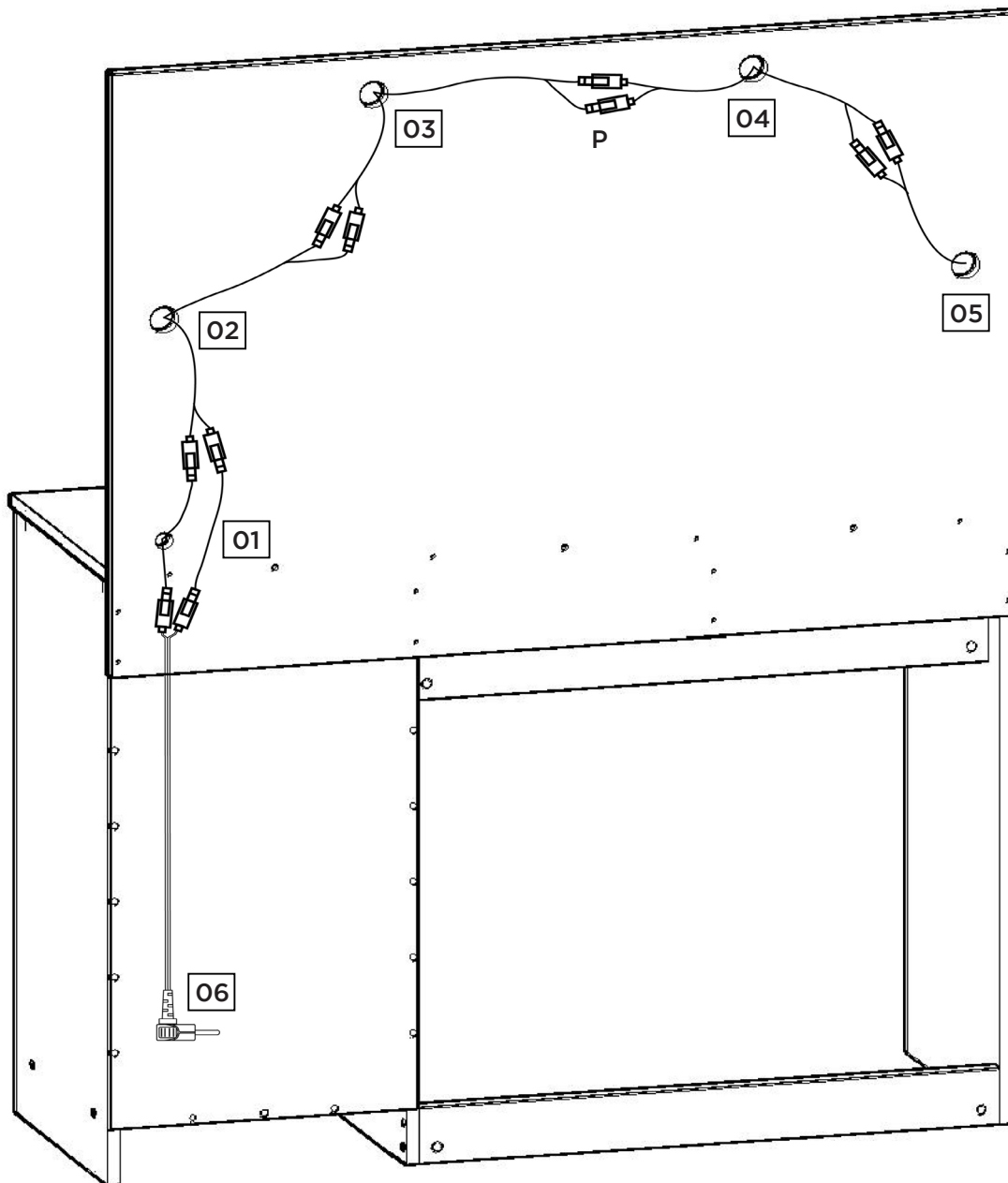

Detalhe da fiação do Kit Luminária Led.

Detalle del cableado del Kit Luminaria Led.

Detail of wiring Kit Led lamp.



Atenção: A colocação do LED deve seguir conforme demonstrado a cima respeitando a sequência da numeração. Esta sequência de numeração acompanha a instrução do Kit LED.

Atención: La colocación del LED debe seguir como se muestra arriba respetando la secuencia de la numeración. Esta secuencia de La numeración acompaña la instrucción del Kit LED.

Caution: The LED placement must follow as shown in the respect the sequence of numbering. This sequence of number accompanies the LED Kit instruction.

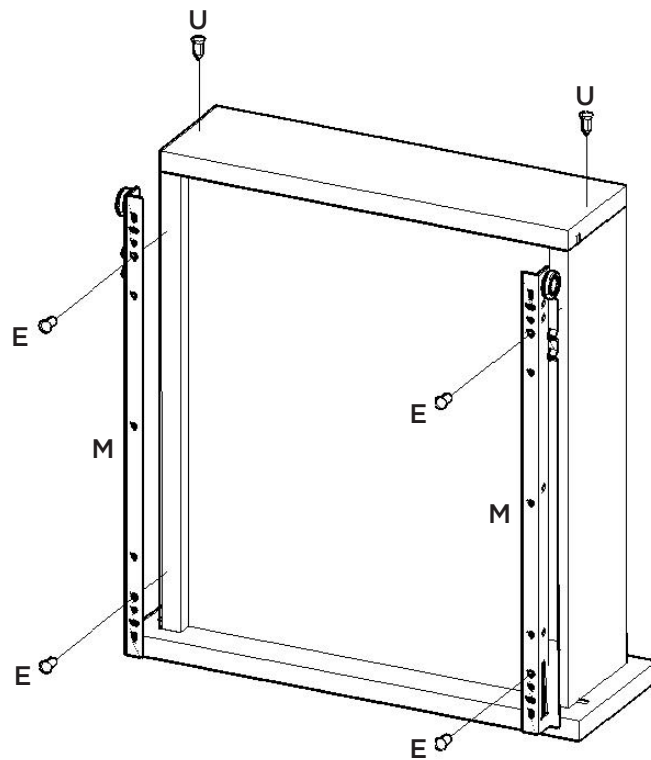
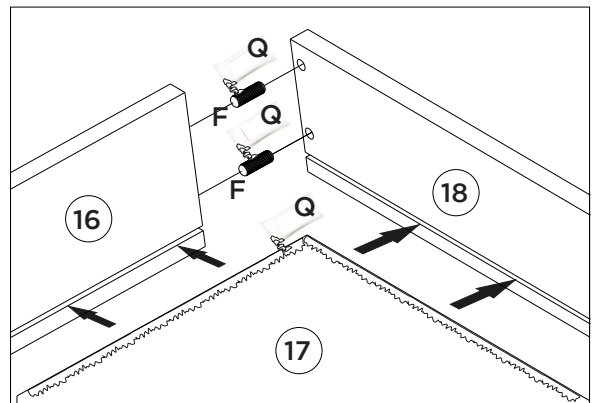
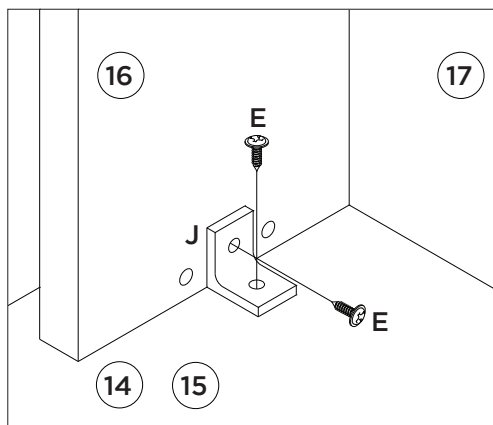
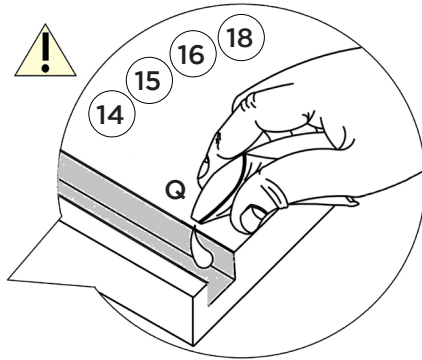
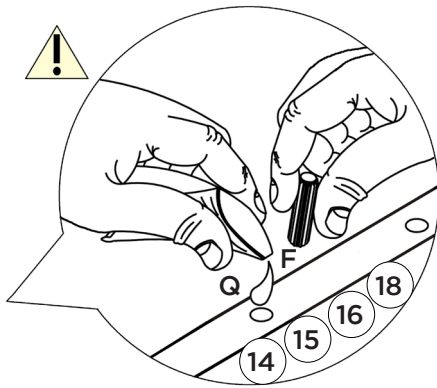
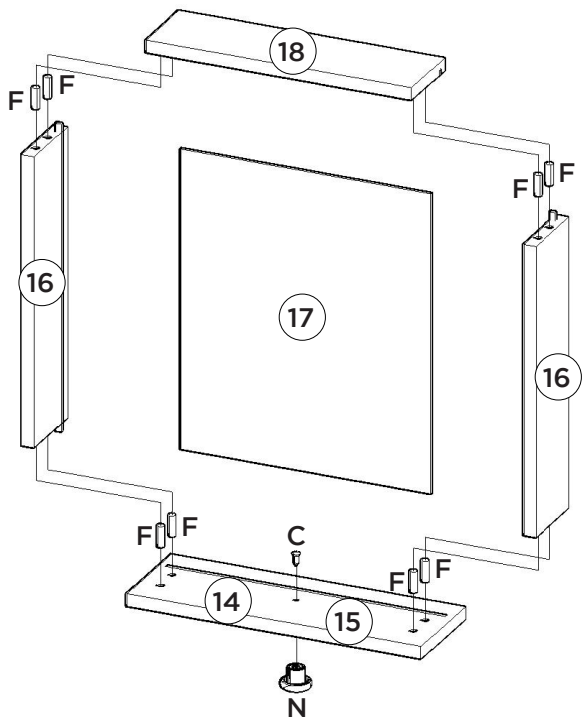

Utilizar componentes abaixo para que sejam conferidos (Escala 1:1)

El uso de componentes a continuación con el fin de conceder (Escala 1:1)

Use components below to be checked (Scale 1: 1)

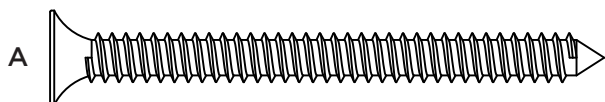

Parafuso 4,5x50mm CHT.

Tornillo 4,5x50mm CHT
Screw 4,5x50mm CHT.



Parafuso 3,5x40mm CHT.

Tornillo 3,5x40mm CHT.
Screw 3,5x40mm CHT.

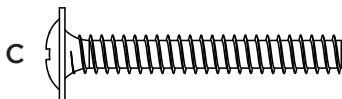

Parafuso 3,5x25mm FLA.

Tornillo 3,5x25mm FLA.
Screw 3,5x25mm FLA.

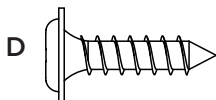

Parafuso 3,5x14mm FLA.

Tornillo 3,5x14mm FLA.
Screw 3,5x14mm FLA.

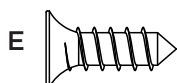

Parafuso 3,5x12mm CHT.

Tornillo 3,5x12mm CHT.
Screw 3,5x12mm CHT.



Cavilha 8x25mm

Cinta 8x25mm
Dowel 8x25mm



Prego 12x12 anelado

Clavo 12x12mm Anillado
Ringed Nails 12x12mm

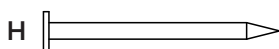

Prego 10x10

Clavo 10x10mm
Nail 10x10mm

Ferragens | Herrajes | Hardware

<p>A 06x </p> <p>Parafuso 4,5x50mm CHT. Tornillo 4,5x50mm CHT. Screw 4,5x50mm CHT.</p>	<p>B 17x </p> <p>Parafuso 3,5x40mm CHT. Tornillo 3,5x40mm CHT. Screw 3,5x40mm CHT.</p>	<p>C 05x </p> <p>Parafuso 3,5x25mm FLA. Tornillo 3,5x25mm FLA. Screw 3,5x25mm FLA.</p>	<p>D 16x </p> <p>Parafuso 3,5x14mm FLA. Tornillo 3,5x14mm FLA. Screw 3,5x14mm FLA.</p>	<p>E 56x </p> <p>Parafuso 3,5x12mm CHT. Tornillo 3,5x12mm CHT. Screw 3,5x12mm CHT.</p>
<p>F 58x </p> <p>Cavilha 8x25mm Cinta 8x25mm Dowel 8x25mm</p>	<p>G 06x </p> <p>Prego 12x12mm Anelado Clavo 12x12mm Anillado Ringed Nails 12x12mm</p>	<p>H 13x </p> <p>Prego 10x10mm Clavo 10x10mm Nail 10x10mm</p>	<p>I 06x </p> <p>Porca cilíndrica Tuerca cilíndrica Cylindrical nut</p>	<p>J 12x </p> <p>Cantoneira plástica Cantonera plástica Plastic angle brackets</p>
<p>K 02x </p> <p>Calço metal 5mm Calzado metálico 5mm 5 mm metal shim</p>	<p>L 02x </p> <p>Dobradiça metal 26mm Bisagra de metal 26mm 26 mm metal hinge</p>	<p>M 04x </p> <p>Corrediça metal 350mm Corredera de metal 350mm Sliding metal 350mm</p>	<p>N 05x </p> <p>Puxador Catar Branco Tirador Catar Blanco Catar White Handle</p>	<p>O 06x </p> <p>Sapata "L" 16x20mm Zapata "L" 16x20mm "L" shoe 16x20mm</p>
<p>P 01x </p> <p>Kit Led com 4 Luminárias Kit Led con 4 Lámparas Led Kit with 4 Lights</p>	<p>Q 02x </p> <p>Sachê de cola Bolsa de pegamento Glue bag</p>	<p>R 07x </p> <p>Adesivo tapa parafuso 10mm Adhesivo tapón de tornillo 10mm Bolt cover adhesive 10mm</p>	<p>S 02x </p> <p>Giz de correção Tiza de corrección Chalk of correction</p>	<p>T 01x </p> <p>Etiqueta resinada Henn Etiqueta resinada Henn Henn resin label</p>
<p>U 08x </p> <p>Parafuso 3,0x30mm CHT. Tornillo 3,0x30mm CHT. Screw 3,0x30mm CHT.</p>				

Item	Caixa Caja Box	Qtd Ctd Qty	Descrição Descripción Description	Medidas (mm) Dimensions (mm) Size (measurements) (mm)
01	1/2	01	Lateral esquerda Lateral izquierda Left side	785x380x15
02	2/2	01	Divisão División Division	785x380x15
03	1/2	02	Travessa estrutural Travesa estructural Structural strut	707x73x15
04	1/2	01	Travessa frontal gaveta Travesa delantera cajón Front tray drawer	707x73x15
05	2/2	01	Divisão das gavetas División de los cajones Drawer partitioning	380x120x15
06	1/2	01	Rodapé frontal Rodapié frontal Front footer	346x73x15
07	1/2	01	Base Base Base	380x346x15
08	1/2	01	Lateral direita Lateral derecha Right side	785x380x15
09	2/2	01	Tampo Tapa Top	1100x397x15
10	1/2	01	Fundo Fondo Bottom	592x370x3
11	2/2	01	Fundo Espelho Fondo de espejo Mirror Background	1096x785x15
12	2/2	01	Espelho com furo Espejo con orificio Mirror with hole	850x480x3
13	1/2	01	Porta Puerta Door	378x356x15
14	2/2	01	Frente de gaveta maior Frente de cajón mayor Largest drawer front	356x192x15
15	1/2	03	Frente de gaveta Frente de cajón Front of drawer	356x120x15
16	1/2	08	Lado de gaveta Lado del cajón Side of drawer	350x90x15
17	1/2	04	Fundo de gaveta Fondo del cajón Drawer bottom	361x302x3
18	1/2	04	Ripa de trás Malla detrás Rear lath	321x90x15